



Analogic Outputs (x8) optically isolated

Ref: 5055-0608-1
Ref: 5055-0608-2

Arion-IO
Technical
specification

Features

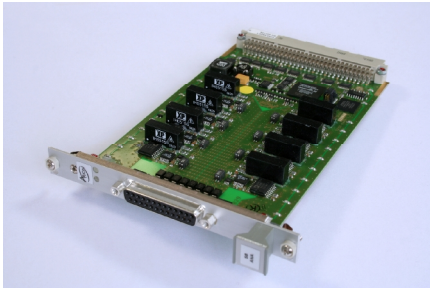

- § 8 analog outputs (separated in 4 groups on the board)
- § Differential or non-differential outputs
- § Noise protection: 50dB
- § Two versions of the board:

	Analog	Analog - E
Reference	5055-0608-1	5055-0608-2
Max. output current	30 mA	30 mA
Range	0V to 5V 0V to 10V -5V to +5V -10V to +10V	0V to 6V 0V to 12V -6V to +6V -12V to +12V



- § Optically isolated: provides a direct connection to industrial equipments
- § Common mode transient immunity of 100V/μs
- § All outputs are protected from transient voltage spikes, short-circuits and overvoltage

Physical and environmental condition

Dimensions: 3U format (length 160mm) x 3T
 Temperature: Industrial range temperature -40°C / +85°C
 Weight: 300g
 Consumption: 700mA for analogical 5V line and 100mA for numerical 3.3V line

Block diagram

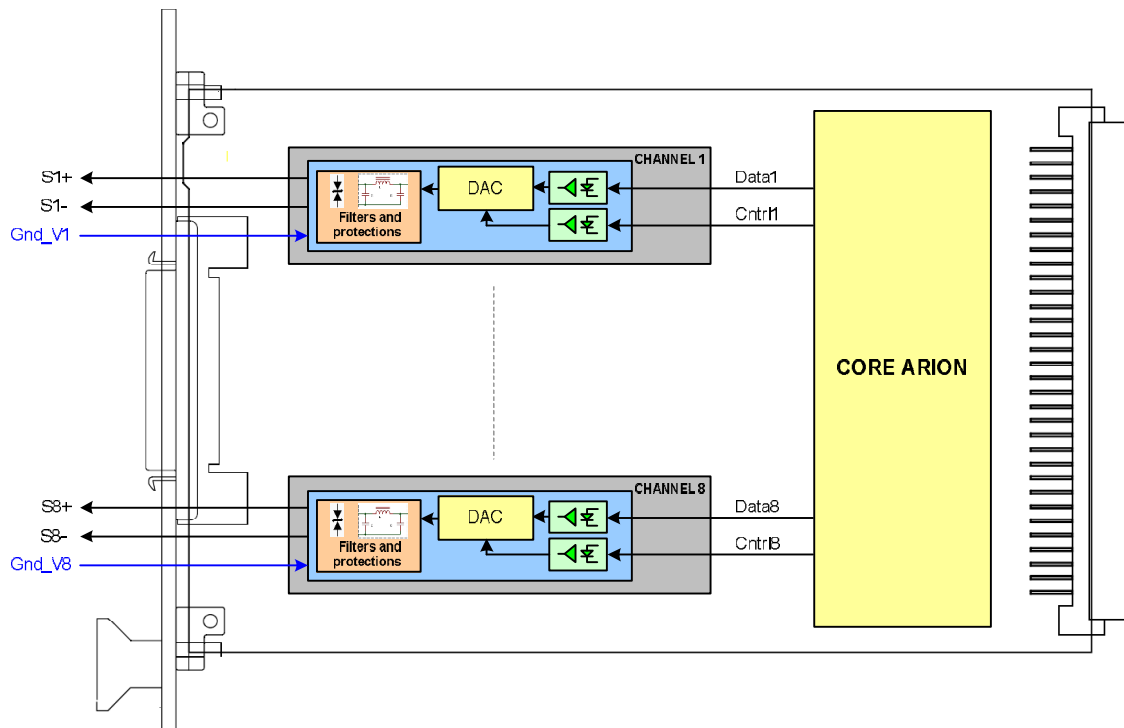



Data coding:

The output is set on 11 bits if the voltage range is positive otherwise it set on 12 bits. It is coded in two's complement binary.

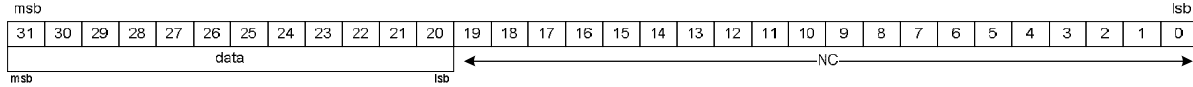

$$\text{lsb value} = \Delta V / 2^n$$

$$\text{data} = \text{Vout} / \text{lsb value}$$

	Mode	ΔV	n	lsb value
ANA	0V to 5V	5V	11	2.44mV
	0V to 10V	10V	11	4.88mV
	-5V to +5V	10V	12	2.44mV
	-10V to +10V	20V	12	4.88mV
ANA-E	0V to 6V	6V	11	2.93mV
	0V to 12V	12V	11	5.86mV
	-6V to +6V	12V	12	2.93mV
	-12V to +12V	24V	12	5.86mV

Arion operating modes

Regarding the data of Arion-IO boards, three operating modes are available.
These 3 modes can ONLY be used in 'Global Channel'; See Configuration documentation for more information.

1. Cyclic mode: default mode

On cyclic trigger, the data are set to the outputs of the board.

Remark: The cyclic trigger is created by a configurable timer. This timer is set during the configuration step.

2. Up-Sampled mode: this mode works like cyclic mode but with N samples.

On cyclic trigger, a sub-cycle is defined to set N data samples to the outputs of the board.

Remark: The N number of samples has to be defined during the configuration step.

3. On demand: this mode is only available on Output Boards.

The data are set to the outputs of the board when the user writes data.



Analog Outputs (x8) optically isolated

Ref: 5055-0608-1
Ref: 5055-0608-2

Arion-IO
Board
installation

Board installation

This board can be installed in any of the 11 slots of the Arion-IO rack. Each position gives a specific address to the board: addresses 3 to 13 are valid (See *Arion-IO Module installation documentation*)
This address is used to define the configuration commands send to the boards. (See *configuration documentation*)

Board Connector - Pin assignment

Front view board's connector:

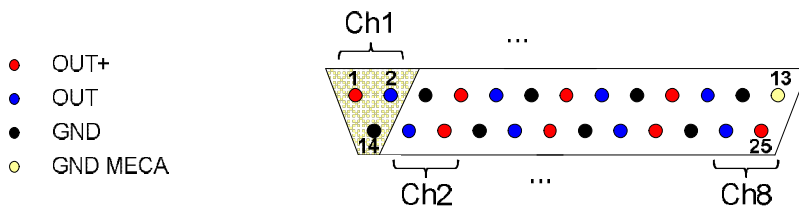

	Pin No	Signal Name
Ch1	1	ANA_OUT1+
	2	ANA_OUT1-
	14	GND_LANE1
Ch2	16	ANA_OUT2+
	15	ANA_OUT2-
	3	GND_LANE2
Ch3	4	ANA_OUT3+
	5	ANA_OUT3-
	17	GND_LANE3
Ch4	19	ANA_OUT4+
	18	ANA_OUT4-
	6	GND_LANE4
Ch5	7	ANA_OUT5+
	8	ANA_OUT5-
	20	GND_LANE5
Ch6	22	ANA_OUT6+
	21	ANA_OUT6-
	9	GND_LANE6
Ch7	10	ANA_OUT7+
	11	ANA_OUT7-
	23	GND_LANE7
Ch8	25	ANA_OUT8+
	24	ANA_OUT8-
	12	GND_LANE8
	13	GND MECA



**Analog Outputs (x8) optically isolated - Ref: 5055-0608-1
Ref: 5055-0608-2**

Signal Modes

Differential:

Signal connected between IN_LANEn+ and IN_LANEn- with GND_EXTn.

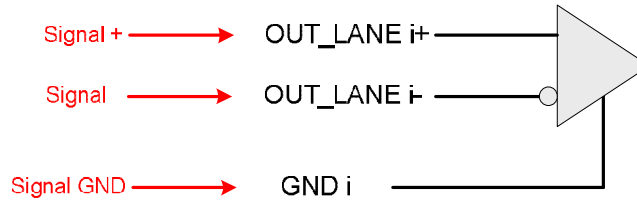

Non-Differential:

Signal connected between IN_LANEn+ and GND_EXTn.
IN_LANEn- must be connected to GND_EXTn.

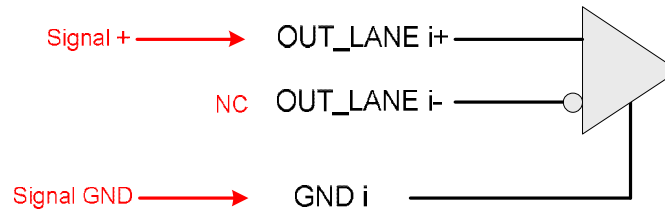

Accessories

Examples of male connector and cap lock to use to make a cable:

Harting products:	
§ Connector	: ref 09 67 025 5604
§ Metal cap lock	: ref 09 67 025 0348

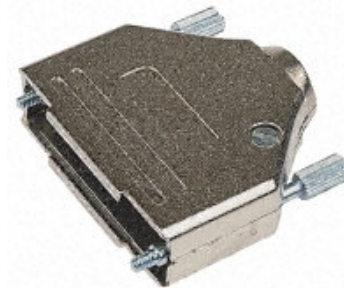



Analog Outputs (x8) optically isolated

Ref: 5055-0608-1
Ref: 5055-0608-2

**Arion-IO
Board
configuration**

Configuration pattern

You must follow the tags and attributes order explained in this pattern to write your ArionIO.xml.

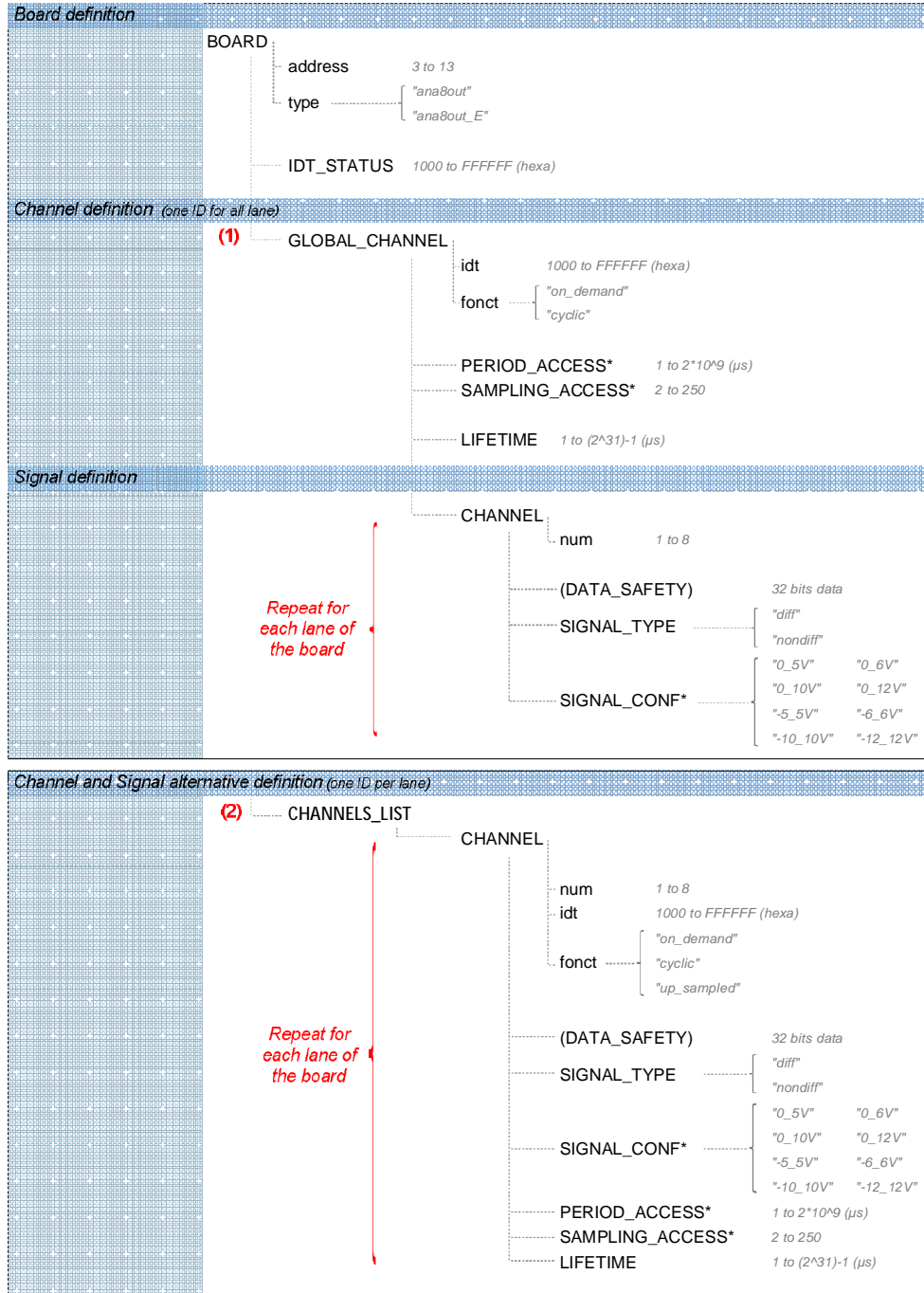

Uppercase = XML tag
Lowercase = XML attribute
Lowercase italic = value
(1) ... (2) = Alternative configuration
() = Optional tag configuration
* = Conditional configuration (see table below)



Parameters description

Name	Value	Fonction	Special condition
<i>Board definition (Tag: BOARD)</i>			
address	integer (3 to 13)	Address of the board	none
type	ana8out ana8out_E	Type of the board	none
IDT_STATUS	1000 to FFFFFFFF	Unique ID of the data status of the board in hexadecimal	none
<i>Channel definition (Tag: GLOBAL_CHANNEL)</i>			
idt	1000 to FFFFFFFF	Unique ID of the data object in hexadecimal	none
fonct	on_demand cyclic up_sampled	Set the fonctional mode of the data object	none
PERIOD_ACCESS	integer (1 to 2*10^9)	LSB=1us (multiple of arion timer_x)	ONLY IF: cyclic or up-sampled mode
SAMPLING_ACCESS	integer (2 to 250)	Number of sample per period. LSB=1us (multiple of arion timer_x)	ONLY IF: up-sampled mode
LIFETIME	integer (1 to (2^31)-1)	Time validity of data object (LSB=1us)	none
<i>Signal definition (Tag: CHANNEL)</i>			
num	integer (1 to 8)	Lane number of the board	none
DATA_SAFETY	32 bits value	Default data value in case of dysfunction	Optional
SIGNAL_TYPE	diff nondif	Configuration of the lane: differential or non-differential connexion	none
SIGNAL_CONF	0_5V 0_10V -5_5V -10_10V	Voltage level of the lane ONLY for a e-ana board	ONLY IF: ana8out
	0_6V 0_12V -6_6V -12_12V	Voltage level of the lane ONLY for a e-ana-E board	ONLY IF: ana8out_E

Remarks:

In GLOBAL_CHANNEL configuration, only one unique ID is set for the 8 channels of the board. All the data are in the ID.

In CHANNEL_LIST configuration, each channel has a unique ID for its data.

In up-sampled mode PERIOD_ACCESS / SAMPLING_ACCESS must be:

- an integer value
- multiple of 2µs and greater than 10µs
- less than 2,097,151µs (2²¹µs)

The tag "IDT_STATUS" and the attribute "idt" can be set as "auto" in the XML. In this case the IDs are created automatically.

idt format: "rack number"+"board number"+"channel number"

IDT_STATUS format: "rack number"+"board number"+100

WARNING: The slots 3 to 13 are numbered from 1 to 11. For example, rack 2 / board in slot 7 / channel 3:

-idt: 25003
-IDT_STATUS: 25100