



Digital Outputs (x32) optically isolated

Ref: 5052-0608-1

Arion-IO
Technical
specification

Features

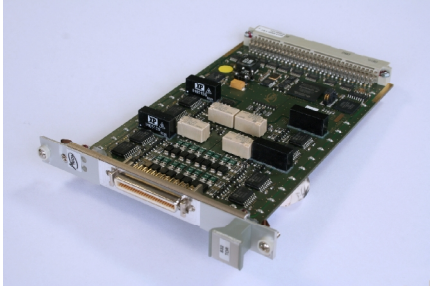

- § 32 digital outputs (separated in 4 groups on the board)
- § I_{max}: 100mA
- § Voltage ranges:

Mode	Low Level	High Level	External supply
TTL	0V to 0.4V	2.4V to 5V	no
Tension	0V to 1V	2V to 60V	yes
Current	0V to 1V	2V to 60V	yes
Inverted Current	2V to 60V	0V to 1V	yes

- § Optically isolated: provides a direct connection to industrial equipments
- § Common mode transient immunity of 100V/μs
- § All outputs are protected from transient voltage spikes, short-circuits and overvoltage



Physical and environmental condition

Dimensions: 3U format (length 160mm) x 3T
 Temperature: Industrial range temperature -40°C / +85°C
 Weight: 300g
 Consumption: 450mA for analogical 5V line and 300mA for numerical 3.3V line

Block diagram

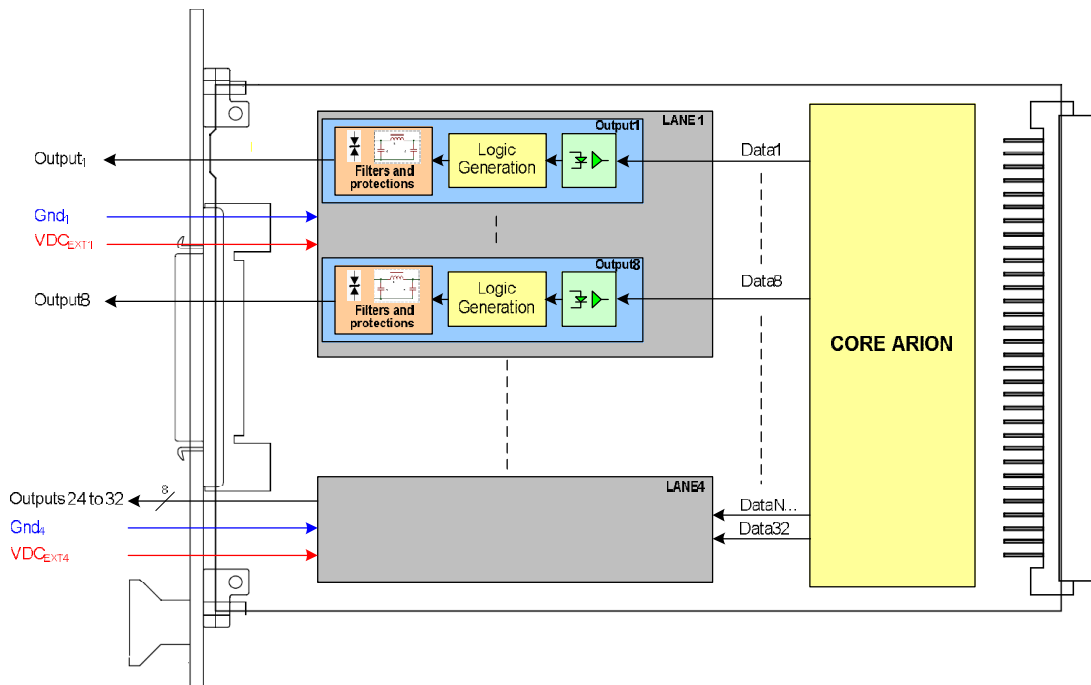

Remark: The 32 outputs are created by 4 different Group. Each output of a Group shares the same ground but is isolated from other Group.



Data coding:

msb																														lsb														
31	30	29	28	27	26	25	24	23	22	21	20	19	18	17	16	15	14	13	12	11	10	9	8	7	6	5	4	3	2	1	0													
out	out	out	out	out	out	out	out	out	out	out	out	out	out	out	out	out	out	out	out	out	out	out	out	out	out	out	out	out	out	out	out	out												
31	30	29	28	27	26	25	24	23	22	21	20	19	18	17	16	15	14	13	12	11	10	9	8	7	6	5	4	3	2	1	0													

Arion operating modes

Regarding the data of Arion-IO boards, three operating modes are available. These 3 modes can ONLY be used in 'Global Channel'; See Configuration documentation for more information.

- 1. Cyclic mode:** *default mode*
On cyclic trigger, the data are set to the outputs of the board.
Remark: The cyclic trigger is created by a configurable timer. This timer is set during the configuration step.
- 2. Up-Sampled mode:** *this mode works like cyclic mode but with N samples.*
On cyclic trigger, a sub-cycle is defined to set N data samples to the output of the board.
Remark: The N number of samples has to be defined during the configuration step.
- 3. On demand:** *this mode is only available on Output Boards.*
The data are set to the outputs of the board when the user writes data.



Digital Outputs (x32) optically isolated

Ref: 5052-0608-1

Arion-IO
Board
installation

Board installation

This board can be installed in any of the 11 slots of the Arion-IO rack. Each position gives a specific address to the board: addresses 3 to 13 are valid (See *Arion-IO Module installation documentation*)
This address is used to define the configuration commands send to the boards. (See *configuration documentation*)

Board Connector - Pin assignment

Front view board's connector:

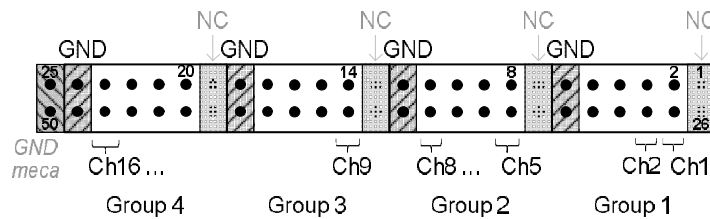

Pin No	Signal Name
1	NC
26	NC
2	OUT_LANE1
27	OUT_LANE2
3	OUT_LANE3
28	OUT_LANE4
4	OUT_LANE5
29	OUT_LANE6
5	OUT_LANE7
30	OUT_LANE8
6	GND_EXT1
31	GND_EXT1
13	NC
38	NC
14	OUT_LANE17
39	OUT_LANE18
15	OUT_LANE19
40	OUT_LANE20
16	OUT_LANE21
41	OUT_LANE22
17	OUT_LANE23
42	OUT_LANE24
18	GND_EXT3
43	GND_EXT3

Pin No	Signal Name
7	NC
32	NC
8	OUT_LANE9
33	OUT_LANE10
9	OUT_LANE11
34	OUT_LANE12
10	OUT_LANE13
35	OUT_LANE14
11	OUT_LANE15
36	OUT_LANE16
12	GND_EXT2
37	GND_EXT2
19	NC
44	NC
20	OUT_LANE25
45	OUT_LANE26
21	OUT_LANE27
46	OUT_LANE28
22	OUT_LANE29
47	OUT_LANE30
23	OUT_LANE31
48	OUT_LANE32
24	GND_EXT4
49	GND_EXT4
25	GND MECA
50	GND MECA



Digital Outputs (x32) optically isolated - Ref: 5052-0608-1

Accessories

The female connector to use is: N10150-3000PE from 3M.

There are several versions of caps lock



§	Plastic	: ref 10350-3210-00
§	Metal	: ref 10350-A200-00
§	Plastic 2 shells	: ref 10350-52F0-008



Digital Outputs (x32) optically isolated

Ref: 5052-0608-1

Arion-IO Board configuration

Configuration pattern

You must follow the tags and attributes order explained in this pattern to write your ArionIO.xml.

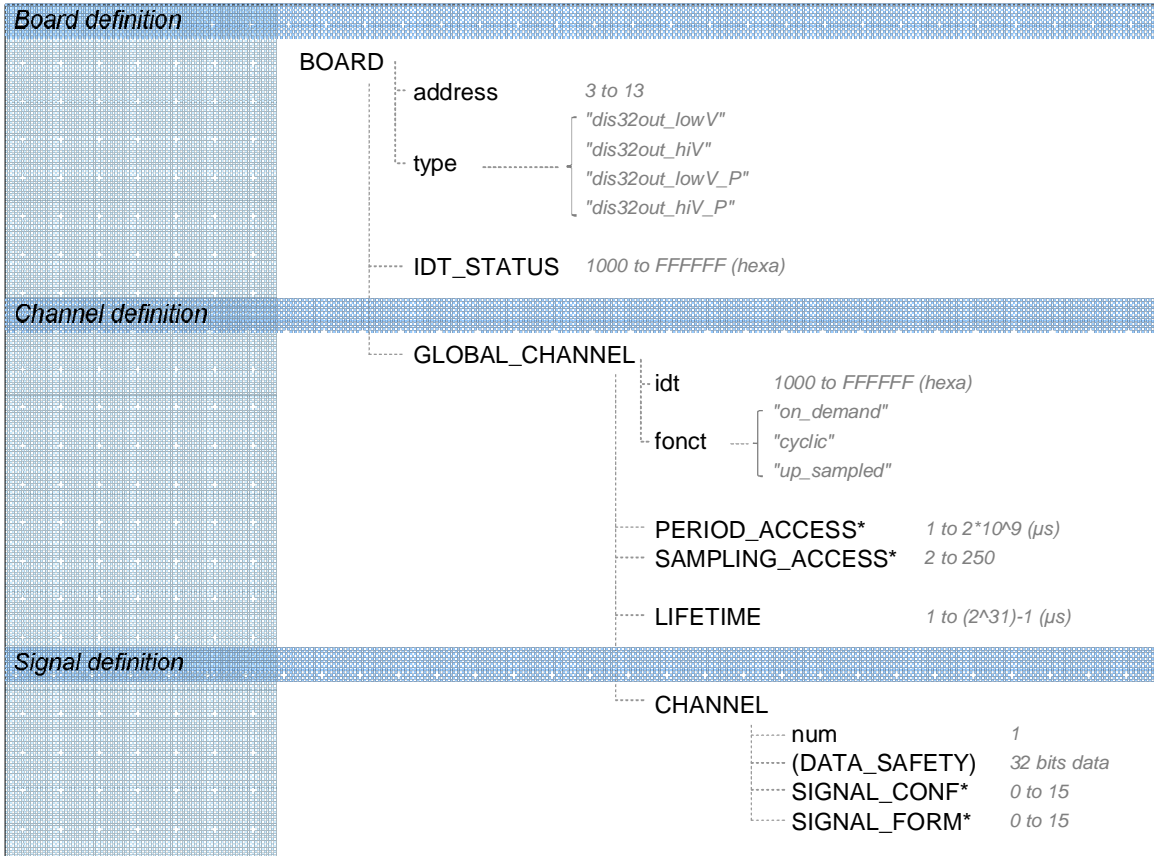

Uppercase = XML tag
 Lowercase = XML attribute
 Lowercase italic = value
 () = Optional tag configuration
 * = Conditional configuration (see table below)



Parameters description

Name	Value	Fonction	Special condition
<i>Board definition (Tag: BOARD)</i>			
address	integer (3 to 13)	Address of the board	none
type	dis32out_lowV dis32out_hiV	dis32out_lowV and dis32out_hiV for old board ref:5052-0608-BT or HT	none
	dis32out_lowV_P dis32out_hiV_P	For board ref:5052-0608-1 (high or low voltage configuration)	
IDT_STATUS	1000 to FFFFFFF	Unique ID of the data status of the board	none
<i>Channel definition (Tag: GLOBAL_CHANNEL)</i>			
idt	1000 to FFFFFFF	Unique ID of the data object	none
fonct	on_demand cyclic up_sampled	Set the fonctional mode of the data object	none
PERIOD_ACCESS	integer (1 to 2*10^9)	LSB=1us (multiple of arion timer_x)	ONLY IF: cyclic or up-sampled mode
SAMPLING_ACCESS	integer (2 to 250)	Number of sample per period. LSB=1us (multiple of arion timer_x)	ONLY IF: up-sampled mode
LIFETIME	integer (1 to (2^31)-1)	Time validity of data object (LSB=1us)	none
<i>Signal definition (Tag: CHANNEL)</i>			
num	1	Number of channel. Always '1' for global_channel.	none
DATA_SAFETY	32 bits value	Default data value in case of dysfunction	Optional
SIGNAL_CONF	integer (0 to 15)	Treshold mode group configuration (TTL=1/Current=0)	none
SIGNAL_FORM	integer (0 to 15)	Output logic group configuration (inverse=1/normal=0)	none

Remarks:

Digital Outputs board can only be configured in GLOBAL_CHANNEL configuration. One unique ID is set for the all 32 channels of the board. All the data are in the same ID.

With this configuration, the tag CHANNEL needs to be configured to set the channels' parameters.

In up-sampled mode PERIOD_ACCESS / SAMPLING_ACCESS must be:

- an integer value
- multiple of 2µs and greater than 10µs
- less than 2,097,151µs (2²¹µs)

The tag "IDT_STATUS" and the attribute "idt" can be set as "auto" in the XML. In this case the IDs are created automatically.

idt format: "rack number"+"board number"+"channel number"

IDT_STATUS format: "rack number"+"board number"+100

WARNING: The slots 3 to 13 are numbered from 1 to 11. For example, rack 2 / board in slot 7 / channel 3:

- idt: 25003
- IDT_STATUS: 25100