



Lvdt/Rvdt Outputs (x3) optically isolated

Ref: 5058-0608-1

Arion-IO
Technical
specification

Features

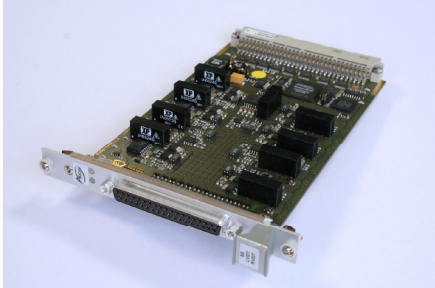

§ 4 operational modes:

- Ø Lvdt
- Ø Rvdt
- Ø Direct command
- Ø Wheatstone Bridge

§ Input/Output Frequencies: 4 KHz max.
 § Input voltage (Vex): ± 36,77V (26 Veff)
 § Output voltage (V1, V2): ± 16,69V (11.8 Veff)

§ Optically isolated: provides a direct connection to industrial equipments

§ Common mode transient immunity of 100V/μs

§ All outputs are protected from transient voltage spikes, short-circuits and overvoltage



Physical and environmental condition

Dimensions: 3U format (length 160mm) x 3T
 Temperature: Industrial range temperature -40°C / +85°C
 Weight: 300g
 Consumption: 800mA for analogical 5V line and 300mA for numerical 3.3V line

Block diagram

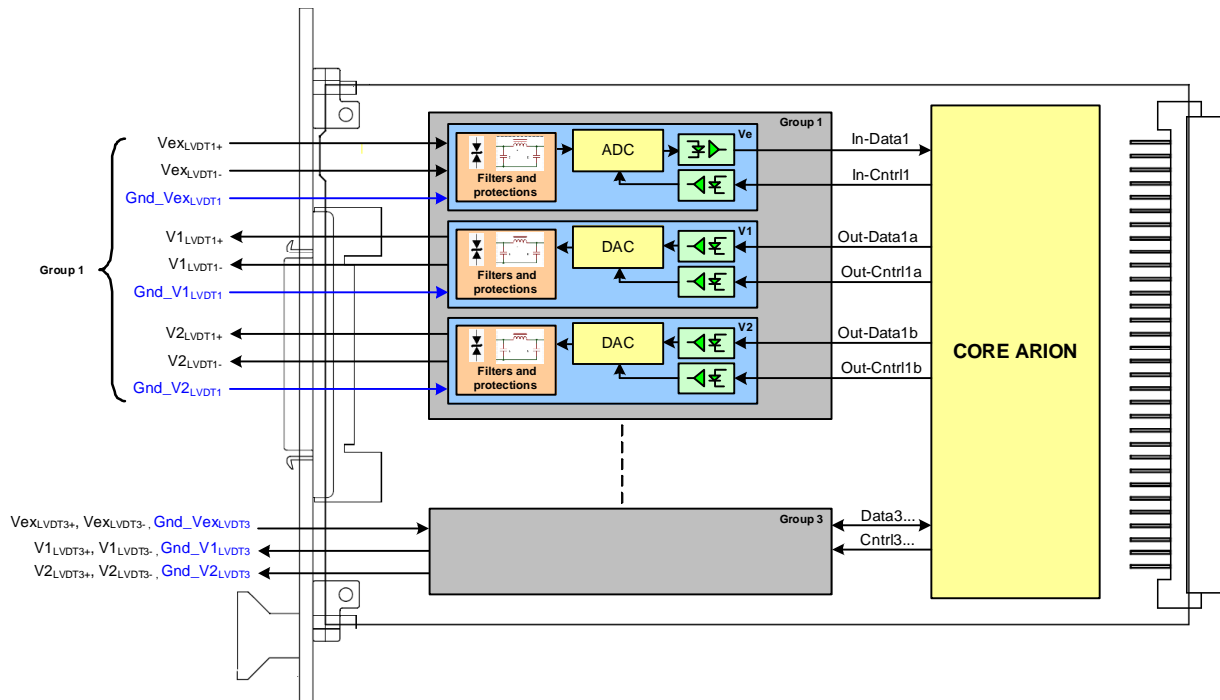



Lvdt/Rvdt Outputs (x3) optically isolated - Ref: 5058-0608-1

Principle

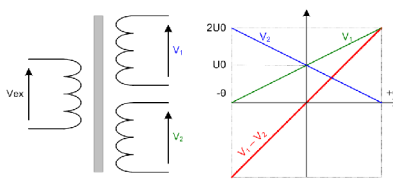
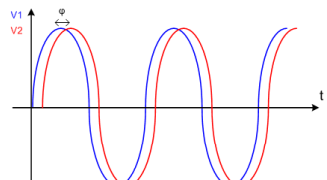
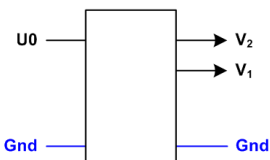
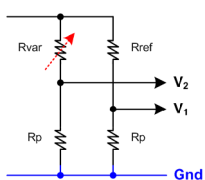
Lvdt		
	$U0 = Coef * Vex$ $V1 = U0 * (1 + k1)$ $V2 = U0 * (1 - k1)$ $k1 : [-\theta ; +\theta]$	With : $0 \leq Coef \leq 1$ $1 \leq k1 \leq +1$
Rvdt		
	$U0 = Coef * Vex$ $V1 = V2 = U0$ $\phi = k1$	With : $0 \leq Coef \leq 1$ $1 \leq k1 \leq +1$
Direct Command		
	$U0 = Coef * Vex$ $V1 = k1 * U0$ $V2 = k2 * U0$	With : $0 \leq Coef \leq 1$ $1 \leq k1 \leq +1$ $1 \leq k2 \leq +1$
Wheatstone Bridge		
	$V1 = \frac{U0 * Rp}{Rp + Rref}$ $V2 = \frac{U0 * Rp}{Rp + Rvar}$ $U0 = Coef * Vex$ $V1 = k1 * U0$ $V2 = k2 * U0$	With : $0 \leq Coef \leq 1$ $0 \leq k1 \leq +1$ $0 \leq k2 \leq +1$

Data coding:

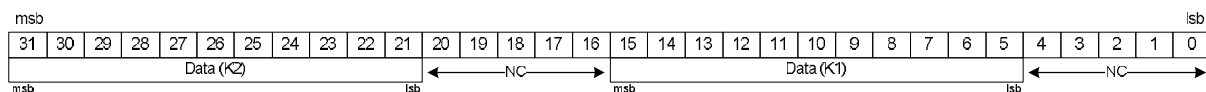

K1 and K2 in two's complement binary with LSB = 0,5. The Coef value is set during the configuration step.

Arion operating modes

Regarding the data of Arion-IO boards, three operating modes are available.

These 3 modes can be used in 'Global Channel' or 'Channel List'; See Configuration documentation for more information.

1. Cyclic mode: default mode

On cyclic trigger, the data are set to the outputs of the board.

Remark: The cyclic trigger is created by a configurable timer. This timer is set during the configuration step.

2. Up-Sampled mode: this mode works like cyclic mode but with N samples.

On cyclic trigger, a sub-cycle is defined to set N data samples to the outputs of the board.

Remark: The N number of samples has to be defined during the configuration step.

3. On demand: this mode is only available on Output Boards.

The data are set to the outputs of the board when the user writes data.



Lvdt/Rvdt Outputs (x3) optically isolated

Ref: 5058-0608-1

Arion-IO
Board
installation

Board installation

This board can be installed in any of the 11 slots of the Arion-IO rack. Each position gives a specific address to the board: addresses 3 to 13 are valid (See *Arion-IO Module installation documentation*)
This address is used to define the configuration commands send to the boards. (See *configuration documentation*)

Board Connector - Pin assignment

Front view board's connector:

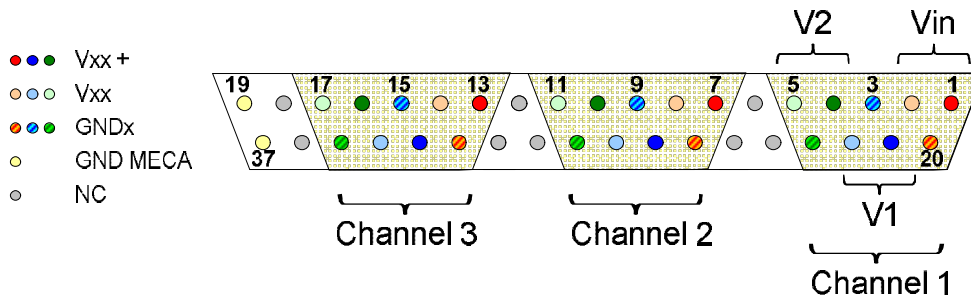

	Pin No	Signal Name
Ch1	1	xVDT1_VE+
	2	xVDT1_VE-
	20	xVDT1_VE_GND
	3	xVDT1_V1+
	21	xVDT1_V1-
	22	xVDT1_V1_GND
	23	xVDT1_V2+
	4	xVDT1_V2-
	5	xVDT1_V2_GND
	6	NC
	24	NC
	25	NC
Ch2	7	xVDT2_VE+
	8	xVDT2_VE-
	26	xVDT2_VE_GND
	9	xVDT2_V1+
	27	xVDT2_V1-
	28	xVDT2_V1_GND
	29	xVDT2_V2+
	10	xVDT2_V2-
	11	xVDT2_V2_GND
		12
	30	NC
	31	NC

	Pin No	Signal Name
Ch3	13	xVDT3_VE+
	14	xVDT3_VE-
	32	xVDT3_VE_GND
	15	xVDT3_V1+
	33	xVDT3_V1-
	34	xVDT3_V1_GND
	35	xVDT3_V2+
	16	xVDT3_V2-
	17	xVDT3_V2_GND
		18
	36	NC
	19	GND MECA
	37	GND MECA



Lvdt/Rvdt Outputs (x3) optically isolated - Ref: 5058-0608-1

Signal Modes

Differential:

Signal connected between IN_LANE_n+ and IN_LANE_n- with GND_EXT_n.

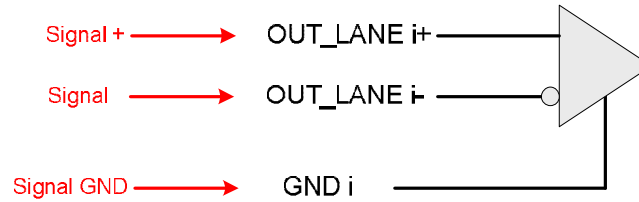

Non-Differential:

Signal connected between IN_LANE_n+ and GND_EXT_n.
IN_LANE_n- must be left unconnected.



Accessories

Examples of male connector and cap lock to use to make a cable:

Harting products:

§ Connector	: ref 09 67 037 5604
§ Metal cap lock	: ref 09 67 037 0348

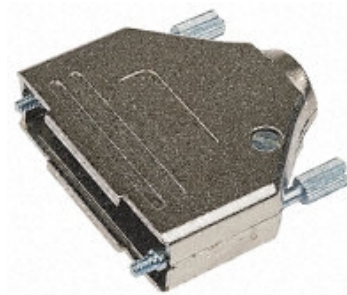



Lvdt/Rvdt Outputs (x3) optically isolated

Ref: 5058-0608-1

**Arion-IO
Board
configuration**

Configuration pattern

You must follow the tags and attributes order explained in this pattern to write your ArionIO.xml.

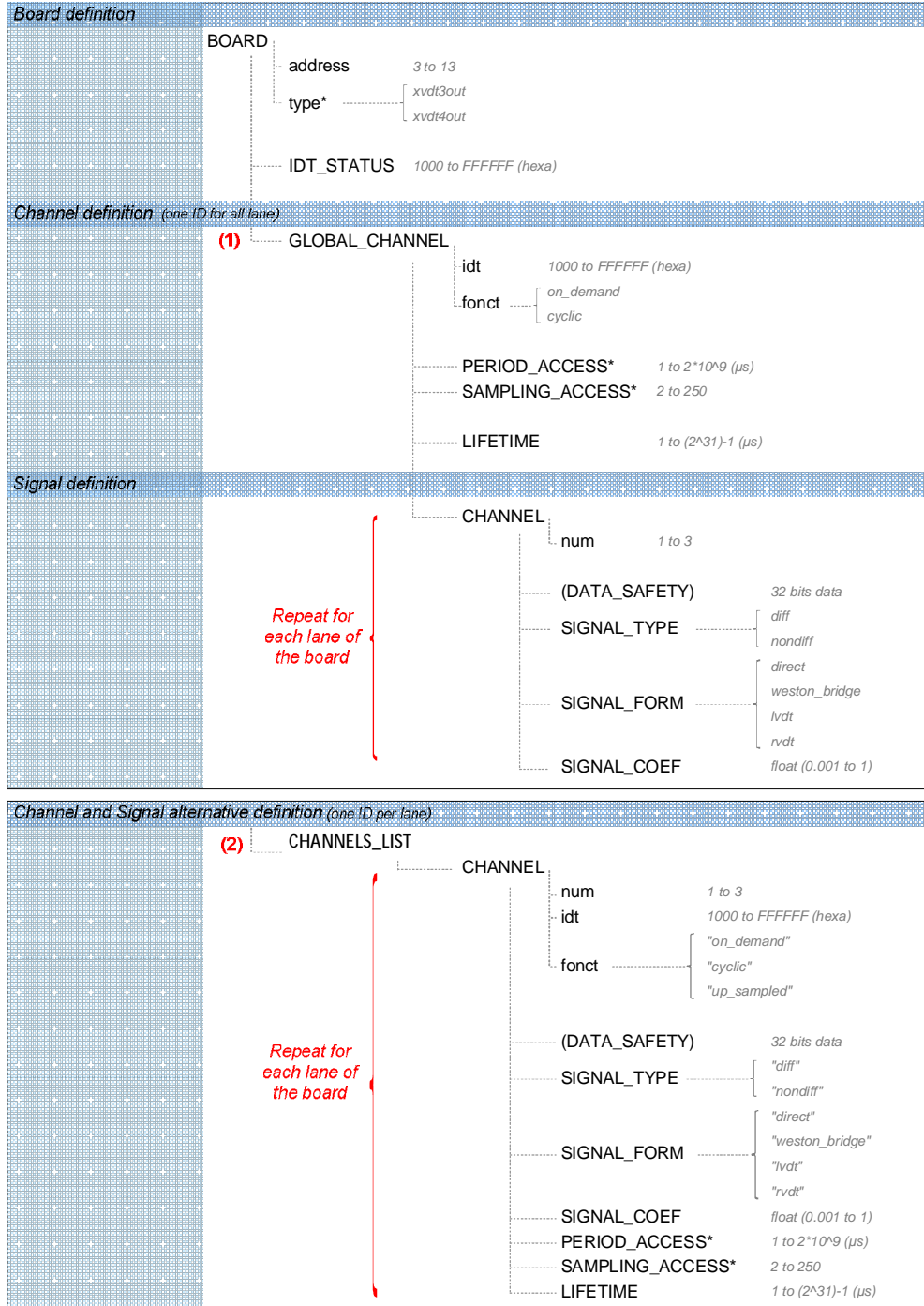

- Uppercase = XML tag
- Lowercase = XML attribute
- Lowercase italic = value
- (1) ... (2) = Alternative configuration
- () = Optional tag configuration
- * = Conditional configuration (see table below)



Parameters description

Name	Value	Fonction	Special condition
<i>Board definition (Tag: BOARD)</i>			
address	integer (3 to 13)	Address of the board	none
type	xvdt3out xvdt4out	Type of the board (see remark below)	none
IDT_STATUS	1000 to FFFFFFFF	Unique ID of the data status of the board	none
<i>Channel definition (Tag: GLOBAL_CHANNEL, CHANNELS_LIST)</i>			
idt	1000 to FFFFFFFF	Unique ID of the data object	none
fonct	on_demand cyclic up_sampled	Set the fonctional mode of the data object	none
PERIOD_ACCESS	integer (1 to 2*10 ⁹)	LSB=1us (multiple of arion timer_x)	ONLY IF: cyclic or up-sampled mode
SAMPLING_ACCESS	integer (2 to 250)	Number of sample per period. LSB=1us (multiple of arion timer_x)	ONLY IF: up-sampled mode
LIFETIME	integer (1 to (2 ³¹)-1)	Time validity of data object (LSB=1us)	none
<i>Signal definition (Tag: CHANNEL)</i>			
num	1	Number of channel. Always '1' for global_channel.	none
DATA_SAFETY	32 bits value	Default data value in case of dysfunction	Optional
SIGNAL_COEF	float (0.001 to 1)	multiplayer coef for input voltage	none
SIGNAL_TYPE	diff nondiff	Output lane configuration	none
SIGNAL_FORM	direct weston_bridge lvdt rvdt	Output fonctional mode	none

Remarks:

The board has only 3 lanes but due to a bug you must set type="xvdt4out" in the xml. If you use the graphical configuration software, the bug is fixed and you must set type="xvdt3out".

In GLOBAL_CHANNEL configuration, only one unique ID is set for the 3 channels of the board. All the data are in the same ID.

In CHANNEL_LIST configuration, each channel has a unique ID for its data.

In up-sampled mode PERIOD_ACCESS / SAMPLING_ACCESS must be:

- an integer value
- multiple of 2µs and greater than 10µs
- less than 2,097,151µs (2²¹µs)

The tag "IDT_STATUS" and the attribute "idt" can be set as "auto" in the XML. In this case the IDs are created automatically.

idt format: "rack number"+"board number"+"channel number"

IDT_STATUS format: "rack number"+"board number"+100

WARNING: The slots 3 to 13 are numbered from 1 to 11. For example, rack 2 / board in slot 7 / channel 3:

- idt: 25003
- IDT_STATUS: 25100